

APPLICATION AND CONTRACT FOR MEETING ROOM BRANDING



66th ASH Annual Meeting & Exposition

Meeting Dates: December 7-10, 2024
Exhibit Dates: December 7-9, 2024
San Diego Convention Center | San Diego, CA

Submit application to:
exhibitcontracts@spargoinc.com

Contact Information

Company Name.....
Contact..... Title.....
Tel (direct)..... Mobile (required).....
Email (direct)..... Web Site .....
Address.....
City..... State..... Zip..... Country.....

Meeting Room Branding Package (Convention Center Hall A and Hilton Bayfront Indigo Ballroom)

The Convention Center Hall A Meeting Room Branding Package includes corporate-only branded graphics on fabric overlays located on the front-facing wall of the Meeting Room. See the following page for additional details and deadlines.

[ ] Convention Center Hall A Package – \$14,000 # of Packages (Meeting Rooms): \_\_\_\_\_

The Hilton Bayfront Indigo Ballroom Meeting Room Branding Package includes corporate-only branded graphics on fabric overlays located on the front-facing wall of the Meeting Room. See the following page for additional details and deadlines.

[ ] Hilton Bayfront Indigo Ballroom Package – \$14,000 # of Packages (Meeting Rooms): \_\_\_\_\_

Total Cost of all Packages: \$ \_\_\_\_\_

Payment Information

Table with 2 columns: Deposit and Payment Schedule. Rows include: February 1, 2024...50% due for applications submitted prior to February 1, 2024; February 1, 2024 – June 3, 2024...50% due with application; After June 3, 2024...100% due with application; ASH requires payment in full no later than June 4, 2024. Failure to make payments does not release the contracted or financial obligation of Exhibitor.

Cancellation Penalties

Table with 2 columns: Cancellation Penalties. Rows include: Through January 31, 2024...0%; February 1, 2024 – June 3, 2024...50%; After June 3, 2024...100%

Make checks payable to: ASH (Reference Invoice Number on check)
ASH Tax ID: 23-7080568

Mail check payment to:
American Society of Hematology - Exhibits
P.O. Box 70705 • Philadelphia, PA 19176-0705

Overnight check payment to:
American Society of Hematology - Box 70705 - Exhibits
Attn: Box 70705
400 White Clay Center Drive • Newark, DE 19711

Credit Card Payments:
An invoice will be sent via email with instructions to submit a credit card payment online. A 3.5% nonrefundable processing fee will be added to all credit card payments.

Submit application to:
Email: exhibitcontracts@spargoinc.com

Need Help? Contact:
ashexhibits@spargoinc.com
703-631-6200 | 800-564-4220

I acknowledge that as an authorized representative of the above stated Exhibitor, I have received, reviewed, and agree that Exhibitor will comply with the Rules and Regulations. Exhibitor agrees to receive all written and electronic correspondence from ASH, SPARGO, Inc. and official event contractors in reference to the ASH annual meeting and all future ASH events. This application will become a contract upon Exhibitor's authorized signature and ASH's acceptance and approval.

Exhibitor Signature..... Date.....
Printed Name..... Telephone.....

# APPLICATION AND CONTRACT FOR MEETING ROOM BRANDING



## 66th ASH Annual Meeting & Exposition

Meeting Dates: December 7-10, 2024

Exhibit Dates: December 7-9, 2024

San Diego Convention Center | San Diego, CA

Submit application to:

[exhibitcontracts@spargoinc.com](mailto:exhibitcontracts@spargoinc.com)

### Convention Center Hall A Meeting Room Branding Package (Corporate Branding Only)

Must allow for 1/4" bleed on both panels

Fabric Graphic Panel

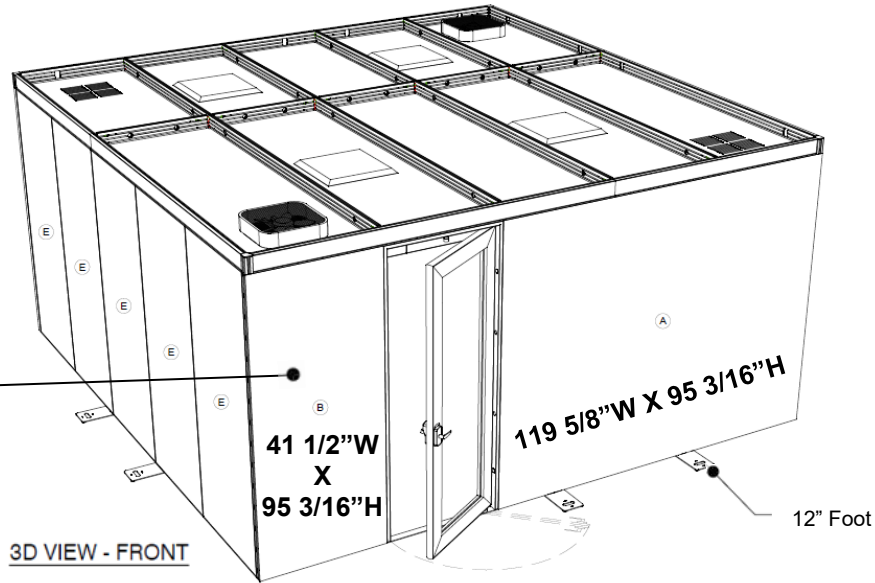

3D VIEW - FRONT

### Hilton Bayfront Indigo Ballroom Meeting Room Branding Package (Corporate Branding Only)

Must allow for 1/4" bleed on both panels

Fabric Graphic Panel

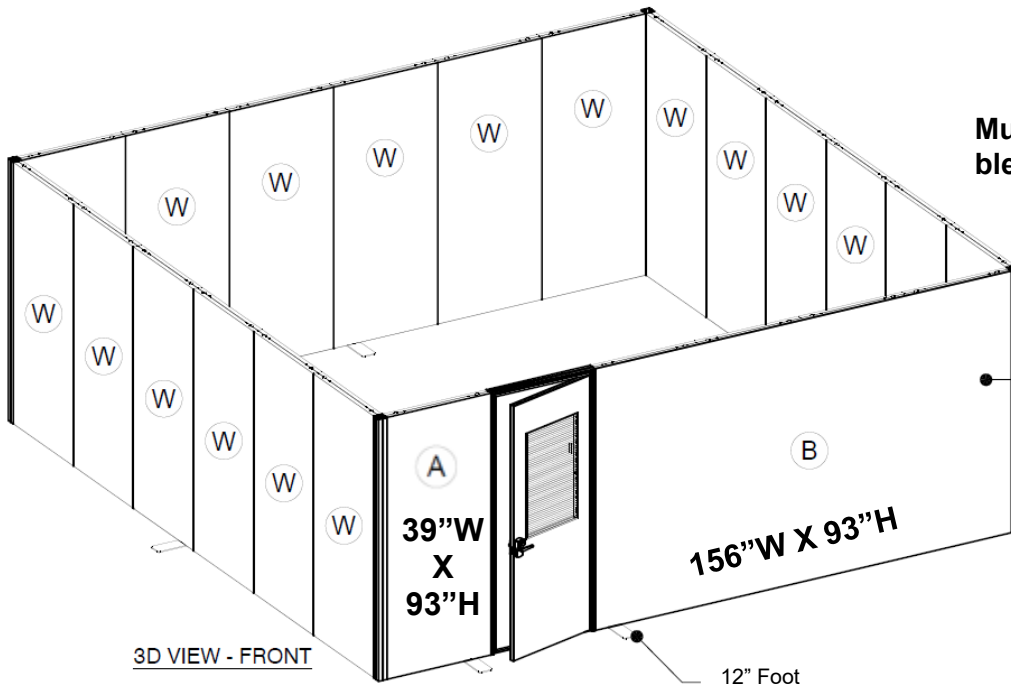

3D VIEW - FRONT

12" Foot

### Meeting Room Branding Package Deadlines

- Monday, September 30, 2024 – Deadline to submit Application and Contract
- Friday, October 18, 2024 – Deadline to submit artwork for ASH review
- Friday, October 25, 2024 – Deadline to submit production ready artwork files
- Friday, November 1, 2024 – Deadline to approve artwork proof and send to production (Failure to meet this deadline will result in production late fees. Exhibitor will be responsible for all production late fees.)